

By Stéphane Chabot, OSP/NSP Business Unit Manager, EXFO
and Michel Leblanc, Researcher, EXFO

While traditional long-haul and metro fiber-optic networks have been laid out using point-to-point networks, fiber-to-the-home (FTTH) architectures, which use passive optical network (PON) technologies, bring in a totally different concept to network testing. This is because FTTH architectures use passive optical splitters between the optical line termination (OLT) and optical network terminations (ONTs) with a traditional coupling ratio of 1:32 (reached with different coupler combinations). Therefore, the common next-generation fiber-optic network architecture is transformed into a point-to-multipoint network (PTMPN) that will have to be deployed, operated and maintained.

This new PTMPN architecture requires enhanced fiber-optic test and measurement equipment in order to manage the installation and maintenance of these networks—from traditional point-to-point power meters, optical sources, visual fault locators (VFLs) and optical time-domain reflectometers (OTDRs), to optical loss test sets (OLTSs) testing at very specific wavelengths such as 1550, 1490 and 1310 nm, where loss budgets are very tight.

This paper will focus primarily on answering critical questions concerning testing FTTP with outside plant equipment, particularly during the deployment and maintenance of PONs. We will discuss cost-effective solutions for the end-user, as well as provide an overview of mathematical splice-loss predictions for PONs obtained by PTMPN OTDR measurements.

Question 1: Which type of test equipment is required at which step in order to certify an FTTx deployment?

The first thing that should be looked at is what should be done during the installation of the fiber-optic network.

Network and Equipment Installation Stage

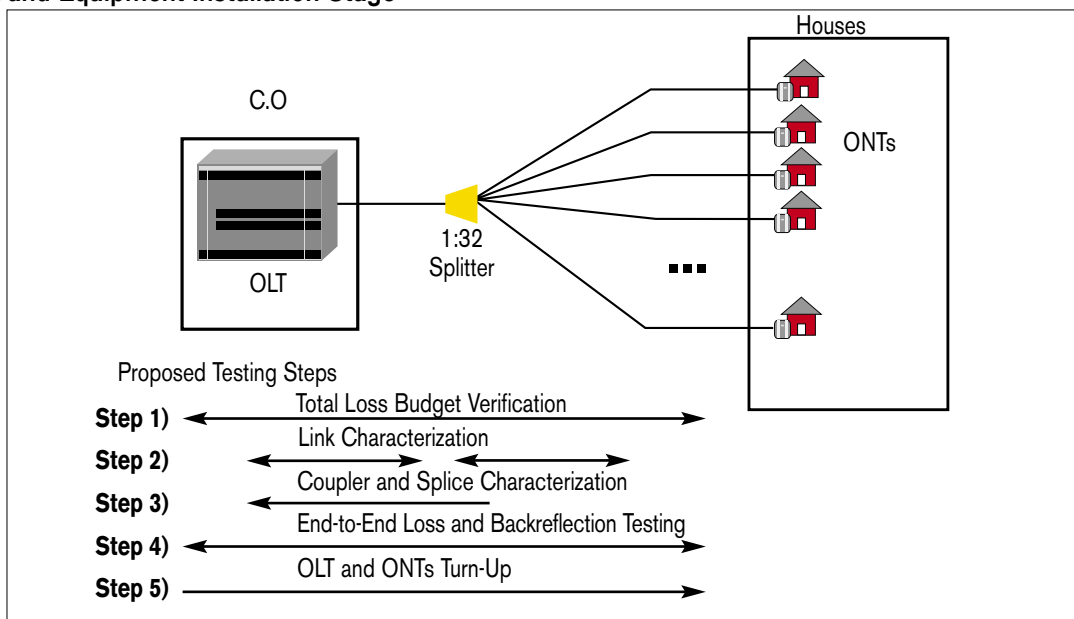

Figure 1: Proposed testing steps for network and equipment installation stage

1) Total Loss Budget

Depending on the type of PON being deployed (25 dB total loss budget for Class-B PON, 30 dB for Class-C PON), each component of the network should be looked at carefully before testing:

- Loss of splitter (1:4, 1:8, 1:16, 1:32), usually the main loss of the system: approximately 16 dB for 1:32 splitters
- Loss of WDMs, typically around 0.7 to 1.0 dB per WDM coupler
- Connector and splice losses, typically around 2.0 to 3.0 dB for the complete link from OLT to ONT
- Fiber loss, which equals attenuation x distance. The maximum distance being limited by the loss budget at worst case attenuation wavelength (1310 nm with around 0.33 dB/km attenuation). The maximum length typically ranges from 4 to 20 km
- Analog video at 1550 nm—suppliers must be careful with loss, reflectance and distance limitations between first and last ONT (3 to 5 dB)
- Total Loss should not exceed the loss budget, otherwise error-free transmission is not possible

2) Link Characterization (individual fibers):

During this step, both loss and fiber attenuation must be measured to ensure that it meets supplier specifications (as well as the loss budget established in point 1). Each fiber should be tested from the OLT at the central office to the splitter (before splicing), as well as from the splitter (before splicing also) to the ONT, bidirectionally if possible. This is important because it allows the averaging of loss values, and because several events, such as mismatched core size, generate different loss levels depending on whether the light comes from one direction or the other.

The measurements will ensure adequate fiber attenuation at each wavelength (1310 nm, 1490 nm and 1550 nm). Note that fiber attenuation should be measured with an OTDR. Typical attenuation figures for new G.652C fibers, which can also be used for PONs, such as SMF-28e™, range from:

- 0.33 dB/km at 1310 nm
- 0.21 dB/km at 1490 nm
- 0.19 dB/km at 1550 nm

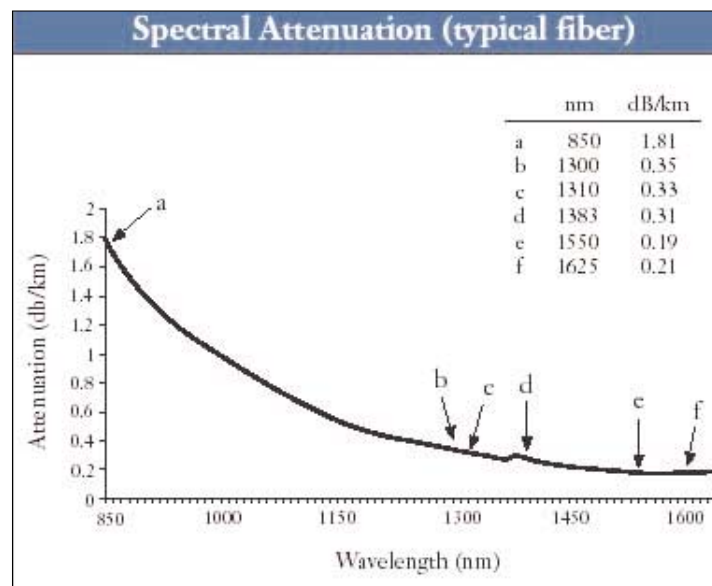

Figure 2: Attenuation per λ on typical G.652C fiber
Source: Corning's SMF-28e spec sheet, July 2003

This characterization will allow you to locate every event, as well as macrobends, that might have been induced during deployment. Macrobends are usually unwanted events that are generated when a fiber is bent above its bend radius (tie-wrap too tight, etc), and can easily be detected by comparing the loss at 1310, 1490 and 1550 nm. Indeed, macrobends will have more significant losses at higher wavelength (1550 nm) than at lower ones (1310 nm).

3) Coupler Ports–Loss and Backreflection Characterization

After splicing the coupler to the fiber coming from the central office, it is recommended, if time permits, to characterize the coupler for loss and backreflection to make sure they are in accordance with manufacturer specifications described in point 1 of question 1. Characterization can be performed simply by using an OTDR combined with a bare fiber adaptor and a pulse suppressor box, and testing the fiber from the coupler output ports towards the OLT in the central office in order to characterize the losses of the splitter ports' first events at 1310, 1490 and 1550 nm for each port. Only the use of a pulse suppressor will allow this; otherwise, the losses of the splitter would be within the OTDR dead zone, and won't be able to be characterized.

- Backreflection of coupler ports should be -35 dB or better, as per ITU-T G.983.1

4) End-to-End Loss and Backreflection Testing and Characterization

After splicing fibers between the coupler output ports (or connectorizing them, depending on the budget loss and configuration selected) and connectorizing the fibers at the ONT and OLT locations, key testing for network installation is performed. Indeed, total end-to-end loss, splices loss, connector loss, backreflection and overall reflectance levels will all be measured at this stage.

Bidirectional end-to-end loss testing, from OLT to the ONTs, is done by using a 1310/1490/1550 nm source and power meter, calibrated and referenced at those wavelengths (or with an OLTS that combines both in the same unit, which allows automated bidirectional testing on the same test). This test includes connectors at the OLT, ONT, and at the splitter output ports, if not spliced. A power meter that could give pass/fail (go/no-go) power reading results per transmission lambda (1310/1490/1550 nm), as per preset manufacturer's OLT threshold power values, would help greatly at this stage, since no interpretation of data would be required at this point.

- Maximum end-to-end loss should be below 25 dB for a Class-B PON
- Maximum end-to-end loss should be below 30 dB for a Class-C PON

Splice loss, as well as connector reflectance, can be established by testing with an OTDR from the ONT towards the OLT (again, through the use of a pulse suppressor box) but also from the OLT towards the ONT, in the PTMPN direction. Question 2 below will respond to the feasibility concerns in this complex issue. The OTDR will locate splices, connectors or any other event with high ORL. Of course, a better ORL will help avoid future degradation beyond the acceptable limit. Verify that:

- Backreflection measurement is OK: Telcordia sets an objective of -40 dB, but this assumes that all components are newly installed and that all of them respect the latest Telcordia recommendations. Generally speaking though, a value in the -30 to -35 dB range is sufficient. Values less than -30 dB should trigger corrective action.
- Splice losses should be below 0.1 dB

Testing through splitters is not a problem with a PON-tuned OTDR. In fact, traditional OTDRs identified high losses (between 3 and 7 dB, depending on user settings) as end-of-fibers. By simply modifying the OTDR analysis, leading OTDR manufacturers can test through splitters with losses up to 20 dB.

5) OLT and ONT Turn-Up

Once the optical network has been characterized, the OLT can be turned up. At that point, before any ONT turn-up, power at the ONTs coming from the OLT (typically up to +4 dBm at the ONT) should be verified with a power meter that could give pass/fail (go/no-go) power reading result per transmission lambda (1310/1490/1550 nm), as per preset manufacturer OLT threshold power values.

Maintenance Stage

By now, the system is up and running, which means that any testing that might affect transmission quality must be avoided; otherwise, customers could suffer loss-of-service (LoS). On-duty personnel at the network operation center will very quickly identify outages, since all active ONTs are automatically pinged at each allocated time slot. No optical-fiber monitoring system is thus required for PON network monitoring.

1) Interpreting ONT Outages (to houses) When Only Some Are Out (1 to 32)

After checking the power levels at one of the closest faulty ONTs (at 1310, 1490 and 1550 nm), two possibilities arise:

- Power is strong and in accordance with working power thresholds, which means that it is probably the ONT hardware that is in trouble.
- Power is weaker than expected according to the power thresholds per λ at this point, which means that there is continuity on the fiber (i.e., no fiber break). In this case, an OTDR should not be used from the ONTs towards the coupler, since the OTDR laser power could interfere with OLT's digital and analog signals, and result in LoS for those houses. It is thus recommended to use maintenance and troubleshooting equipment such as live fiber detectors (LFD) with adapted fiber-type heads (250 μ m, 900 μ m and 3 mm, depending on test point) to verify total power levels (power per λ not possible) at different potential macrobending points, or visual fault locators (VFLs), in order to pinpoint with a red visible light where the fiber is bent beyond its specified bending radius, etc.

2) Interpreting ONT Outages (to houses) When All ONTs Are Out

Faults of this nature can usually be easily pinpointed and linked to either the OLT being out of order, or to a major fault (i.e., break, etc.) that has occurred on the fiber between the OLT at the central office and the splitter input port. Testing with an OTDR at 1550 nm through the connectorized fiber at the central office should help locate the area of the major fault very quickly. No LoS can be generated, since the network is already out.

Question 2: With a PON OTDR, is it possible to test from the central office's OLT towards the splitter, all the way to the ONTs?

It is possible to test a PTMPN with a PON OTDR. This is clearly demonstrated in the two examples shown below (Figures 3 through 9 on Network Installation and Maintenance Stage).

- **Application:** Saves as-built fiber-optic PON network diagram for future reference, and allows testing from the central office (instead of just from the ONTs) for:
 - Splitter loss
 - Connector ORL
 - End-to-end
 - Loss
 - Backreflection
 - Section attenuation

These tests also allow for the computing of key bidirectional information on those elements.

- Challenges:** The most challenging part of testing PTMPN is the analysis that has to be done afterwards because of the intrinsic nature of that test. Indeed, OTDRs are designed to get Rayleigh backscattering from one span (point-to-point)—not from many spans that all add up (up to 32 in that case)—back to the main fiber between the OLT and the splitter to give results as shown below in Figures 5 and 9.

Example #1

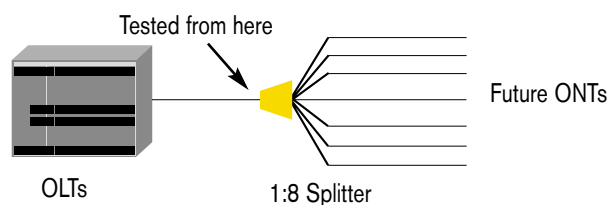

Figure 3: Installation example: 1 x 8 splitter, 5 fibers terminated

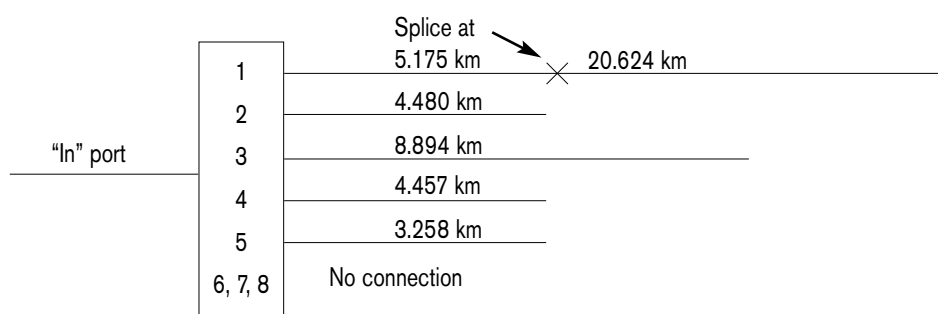

Figure 4: Logical layout of example #1

Results

As shown in Figures 5 and 6 below, the PTMPN was characterized and the 10.8 dB loss from the 1:8 splitter didn't generate an end-of-fiber. All branches were properly located:

- Branch #1's end was detected and positioned at 20.537 km (event #6)
- Branches #2 and 4's ends were detected and positioned at 4.503 km (one event with a 275 ns pulse width) (event #3)
- Branch #3's end was detected and positioned at 8.905 km (event #5)
- Branch #5's end was detected and positioned at 3.267 km (event #2)
- Internal branch event of fiber #1 was detected and positioned at 5.174 km (event #4)

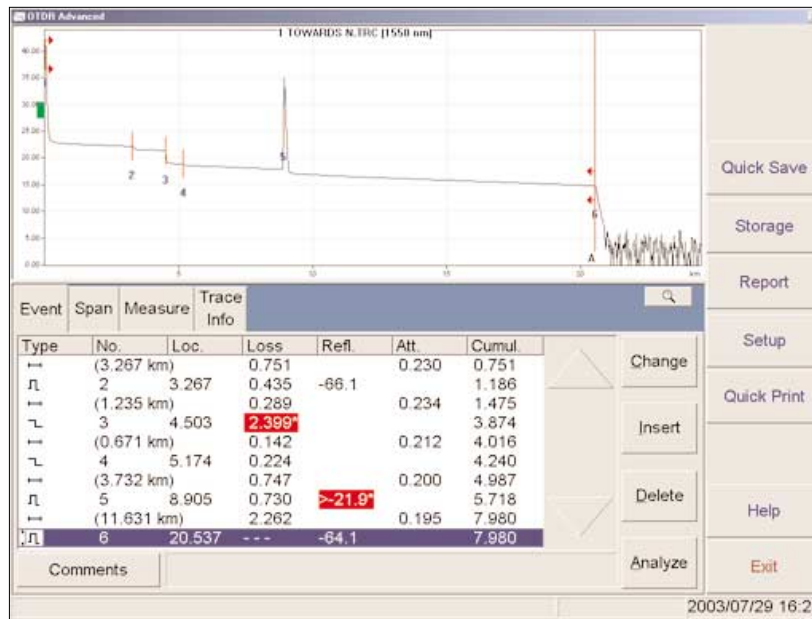

Figure 5: OTDR results for test layout #1

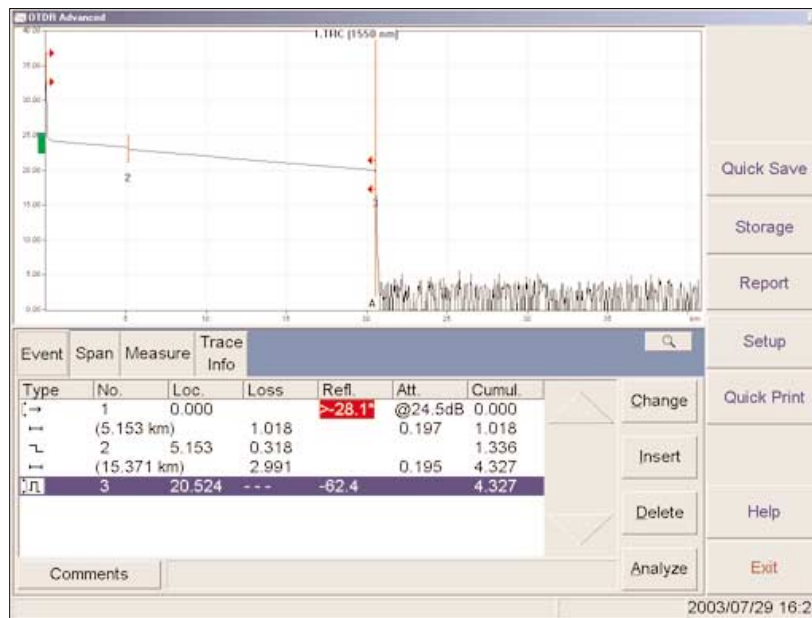

Figure 6: Fiber #1 only

Example #2

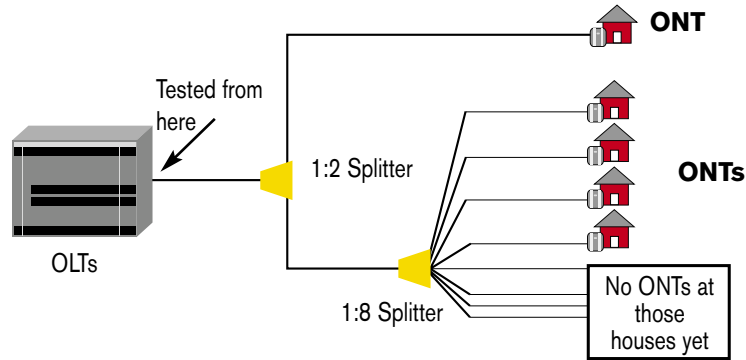

Figure 7: Maintenance example: 1 x 2 combined with 1 x 8 splitters

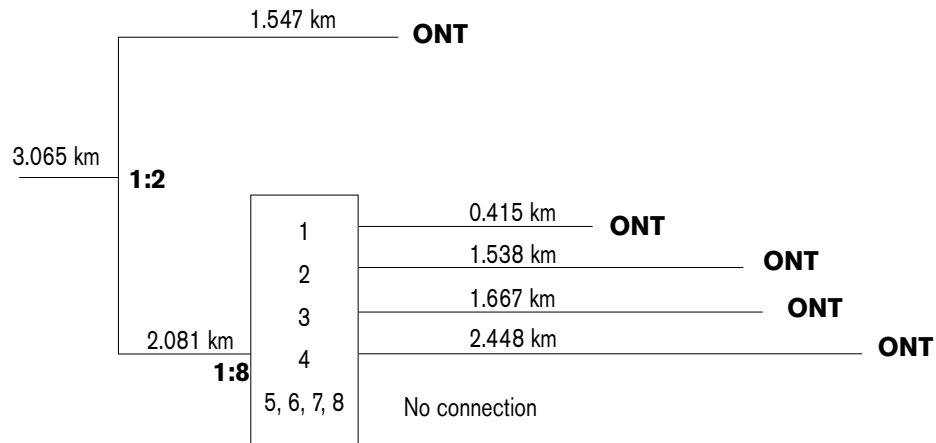

Figure 8: Logical layout of example #2

Results

As shown in Figure 9 below, the PTMPN was characterized and the combined losses of the 1:2 and 1:8 splitters didn't generate an end-of-fiber. All branches were properly located:

- 1:2 splitter was detected and positioned at 3.065 km
- Upper ("North") 1:2 branch's end was detected and positioned at 4.612 km (logical, since 3.065 km + 1.547 km = 4.612 km)
- 1:8 splitter was detected and positioned at 5.145 km (logical, since 3.065 km + 2.081 km = 5.145 km)
- Branch #1's end of 1:8 splitter was detected and positioned at 5.560 km (logical, since 3.065 km + 2.081 km + 0.415 km = 5.145 km)
- Branch #2's end of 1:8 splitter was detected and positioned at 6.683 km (logical, since 3.065 km + 2.081 km + 1.538 km = 6.684 km)
- Branch #3's end of 1:8 splitter was detected and positioned at 6.812 km (logical, since 3.065 km + 2.081 km + 1.667 km = 6.812 km)
- Branch #4's end of 1:8 splitter was detected and positioned at 7.593 km (logical, since 3.065 km + 2.081 km + 2.448 km = 7.593 km)

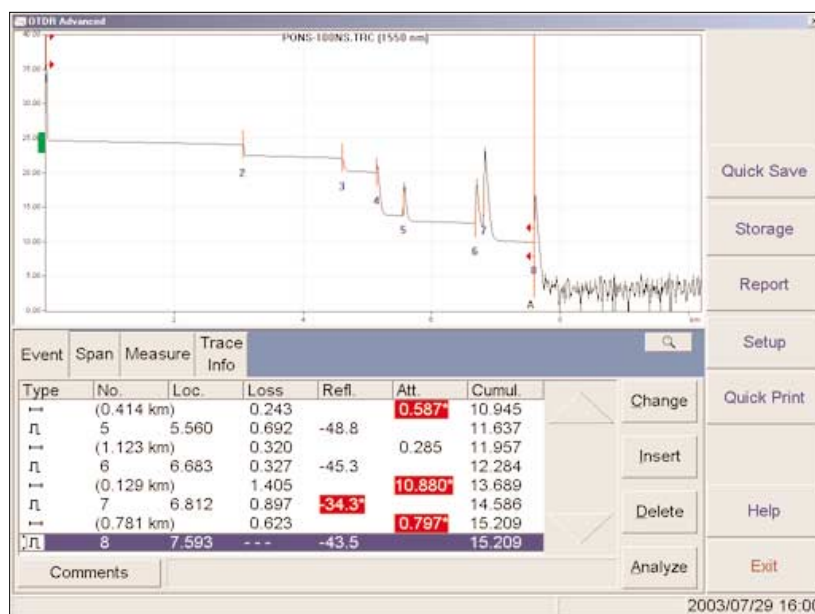

Figure 9: OTDR results for test layout #2

Question 3: How can I predict the impact of total backscattering (all branches) on the loss of an event in a point-to-point network vs. its apparent loss in a PTMPN architecture?

Mathematical Splice Loss Predictions for PONs

When testing a PTMPN with an OTDR, it is important to understand that the OTDR trace is now built from the additive contributions of Rayleigh backscattering from different fibers. Apparent event losses in a PTMPN OTDR trace will be lower for the same event than in a point-to-multipoint network. For example, an apparent splice loss of 0.5 dB on a PTMPN OTDR trace does not imply that a discrete loss of 0.5 dB is located somewhere on the link. It could be due to a larger loss in one of the fibers in the link or even to the end of one of the fibers. We show that the PTMPN OTDR signature can be calculated and predicted. Each real event on an individual fiber of the network (either a splice loss or even an end of fiber) will appear on the PTMPN OTDR trace as follows:

Formula #1: Apparent OTDR splice loss for PONs

$$\text{Loss} = 5 \times \text{Log} \left[\frac{\sum_{j=1}^N 10^{-\text{Cumulative loss before} / 5}}{\sum_{j=1}^N 10^{-\text{Cumulative loss after} / 5}} \right]$$

Each “Cumulative Loss” refers to the loss of the j th network branch when measured with disconnecting all other $N-1$ fibers from the 1XN coupler. The cumulative loss is measured before and after the location of the point of interest on the PTMPN OTDR trace. Note that only branches of that length or more need to be considered.

Loss before and after can be evaluated by simply moving markers on the OTDR trace up to the distance of the event being characterized (e.g.: 3.342 km), and assessing loss before and after that point.

Example #3:

If we look at the splice at 5.175 km on logical layout #1, the loss of that splice alone is 0.318 dB (displayed in Figure 6). But, as detailed and explained below, the loss of that splice will be different when characterized in a PTMPN. Formula #1 gives:

$$\text{Loss} = 5 \times \text{Log} \left[\frac{10^{-1.02 \text{ dB} / 5} + 10^{-2.59 \text{ dB} / 5}}{10^{-1.34 \text{ dB} / 5} + 10^{-2.59 \text{ dB} / 5}} \right]$$

Where fibers 1 and 3 have a length of at least 5.175 km:

CumLossIn1: 1.02 dB, CumLossOut1: 1.34 dB

CumLossIn3: 2.59 dB, CumLossOut3: 2.59 dB

Results Compared

Loss calculated = 0.21 dB, when compared with PTMPN loss of 0.22 dB, as measured in Figure 5, event #4, and proving the theory.

In conclusion, FTTH networks using PON technology can be characterized and maintained every step of the way using very simple new fiber-optic test and measurement equipment. OTDRs can also be used quite easily not only from the ONTs towards the coupler and OLT at the central office, but also, as demonstrated, from the OLT towards the PTMPN. For that type of network architecture (for PONs in PTMPN), mathematical splice loss predictions have been demonstrated to be accurate and, consequently, can help you properly characterize your networks.

Corporate Headquarters > 400 Godin Avenue, Vanier (Quebec) G1M 2K2 CANADA | Tel.: 1 418 683-0211 | Fax: 1 418 683-2170 | info@exfo.com

Toll-free: 1 800 663-3936 (USA and Canada) | www.exfo.com

EXFO America	4275 Kellway Circle, Suite 122	Addison, TX 75001 USA	Tel.: 1 800 663-3936	Fax: 1 972 836-0164
EXFO Europe	Le Dynasteur, 10/12 rue Andras Beck	92366 Meudon la Forêt Cedex FRANCE	Tel.: +33.1.40.83.85.85	Fax: +33.1.40.83.04.42
EXFO Asia-Pacific	151 Chin Swee Road, #03-29 Manhattan House	SINGAPORE 169876	Tel.: +65 6333 8241	Fax: +65 6333 8242
EXFO China	Beijing New Century Hotel Office Tower Room 1754-1755 No. 6 Southem Capital Gym Road	Beijing 100044 P. R. CHINA	Tel.: +86 (10) 6849 2738	Fax: +86 (10) 6849 2662